

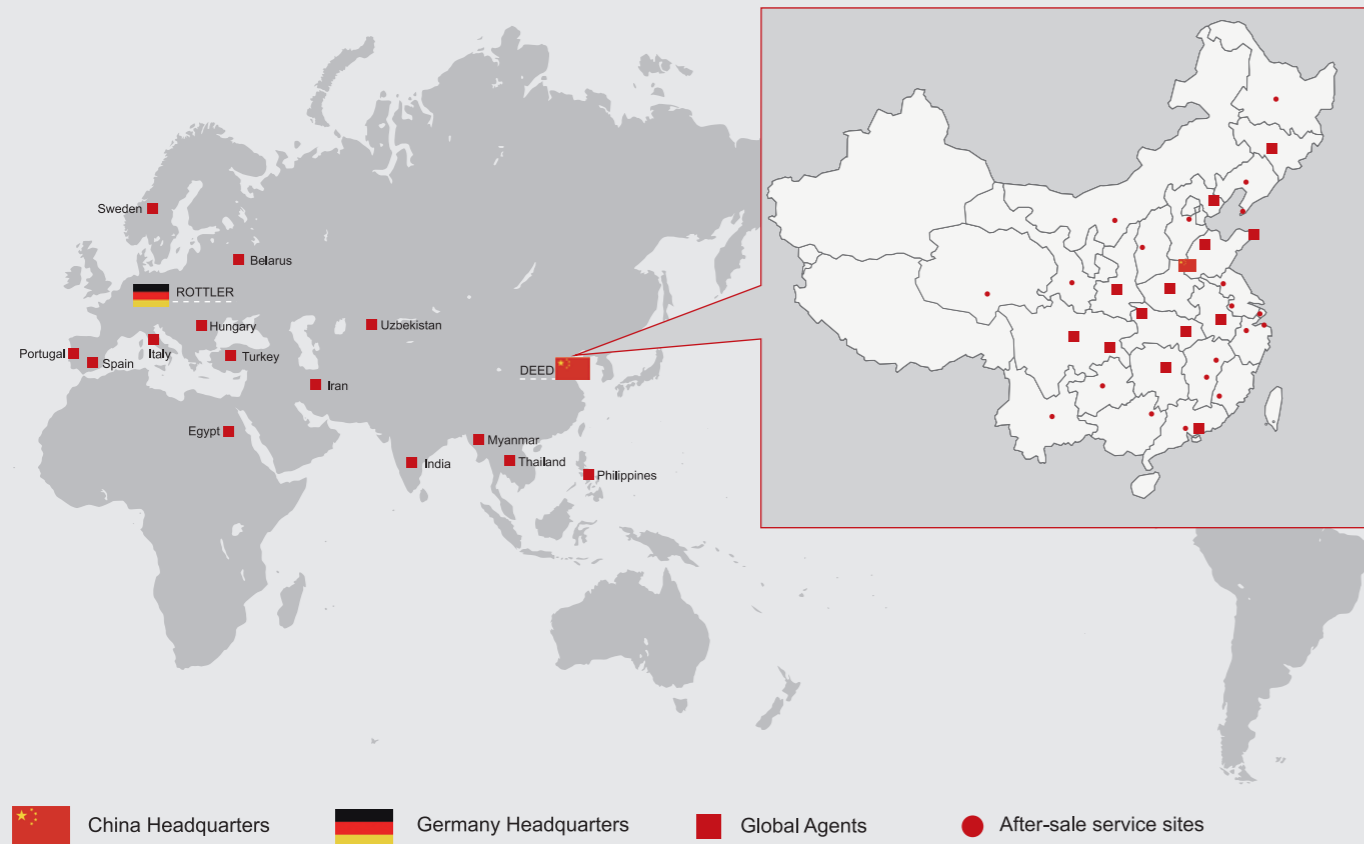

GL Series Fixed Beam Gantry Machining Center  
GMC Series Fixed Beam Gantry Machining Center

Statements, figures and technical parameters in the manual instruction are subject to change without notice in advance.

Global service centers



## GL series

### Cost-effective Gantry Machining Center

GL Series are designed with high rigidity headstock in square-ram structure for stable and strong cutting performance. This series can be widely used in various large structural components manufacture industries for large mould, rail transit, engineering machinery and wind power etc.

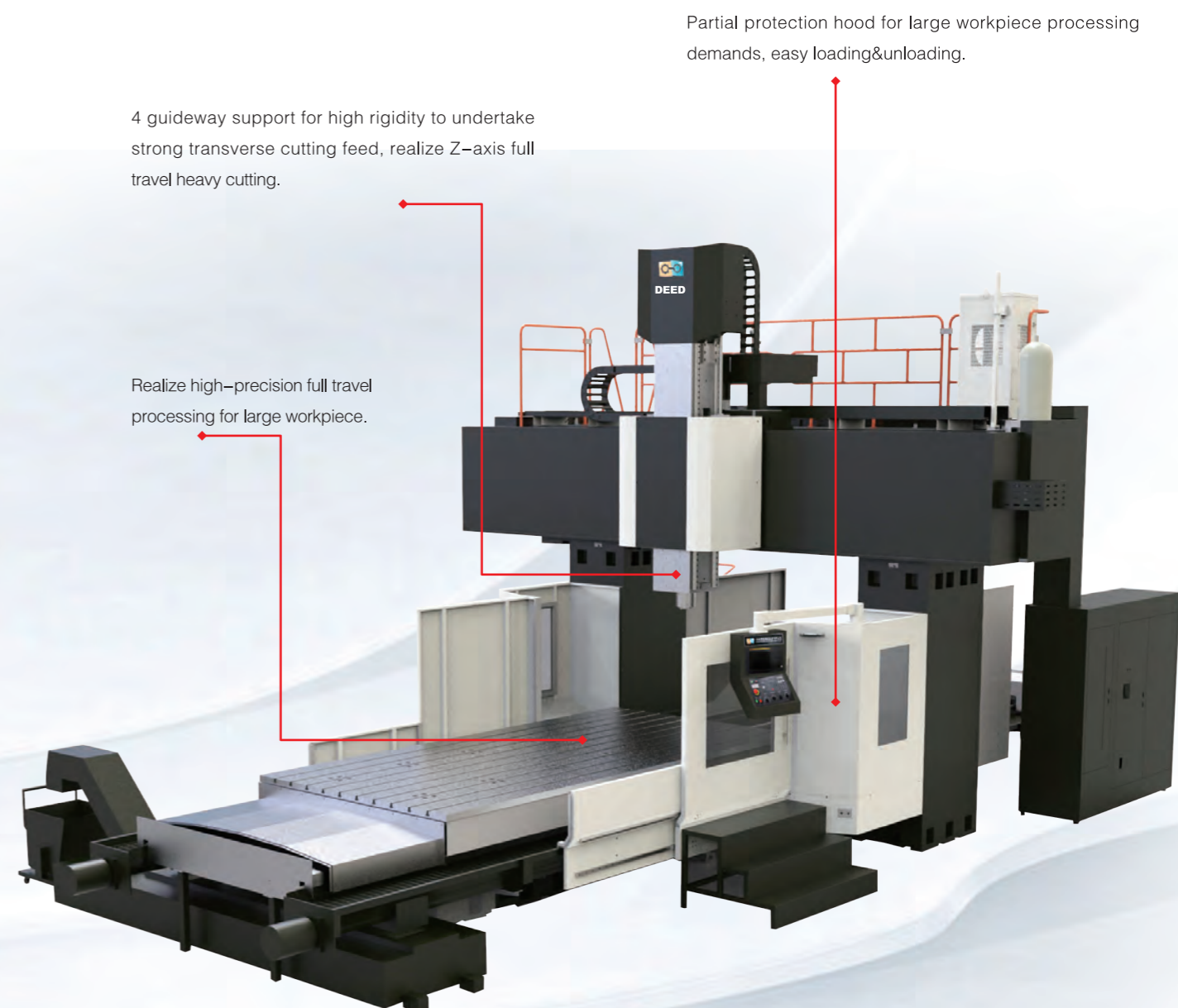

## High Rigidity Design for Full Travel Processing

Machine bed and columns are casted by new material and new technology of UHPC from Germany. Compared to normal grey casting, they can get better vibration absorption, lower heat expansivity and lower thermal conductivity.

Machine beam, slider and headstock are welded in steel-board welding technology from Germany, they can get higher rigidity, lighter moving parts, less movement inertia, then the machine can get better response rate and movement precision.

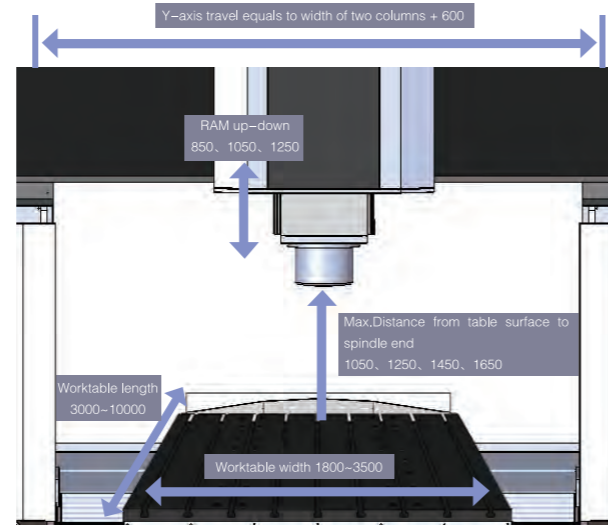

## Direct-drive Spindle

High rigidity direct-drive spindle, with 4 spindle bearings in front and 1 roller bearing in back side, can realize cutting in high speed and large span.

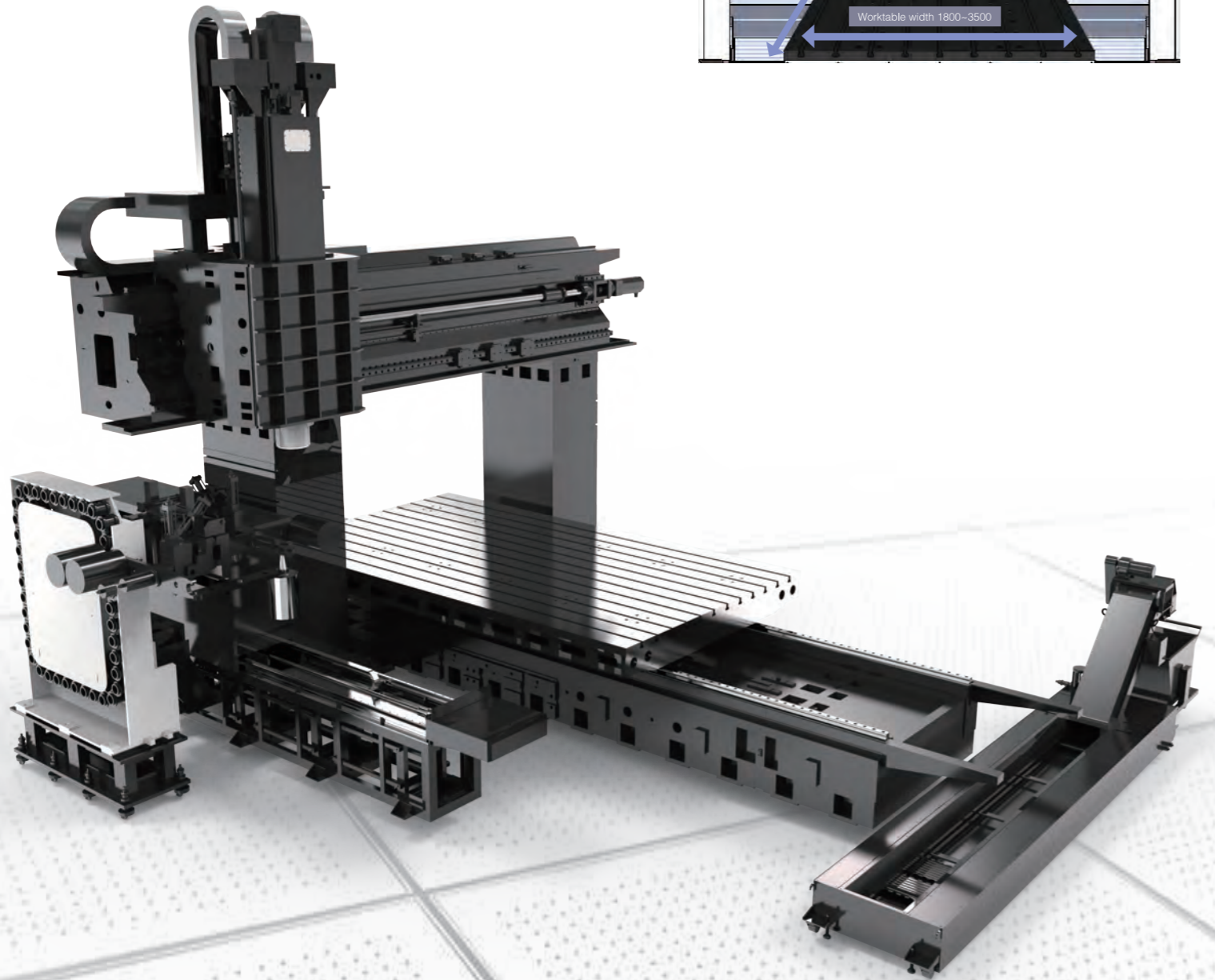

### Standard 6000 r / min spindle

Spindle speed : 6000 r/min  
 Standard : 22/26 kW  
 Spindle Torque : 770/ 910 Nm  
 Cutting Speed : 10 m/min

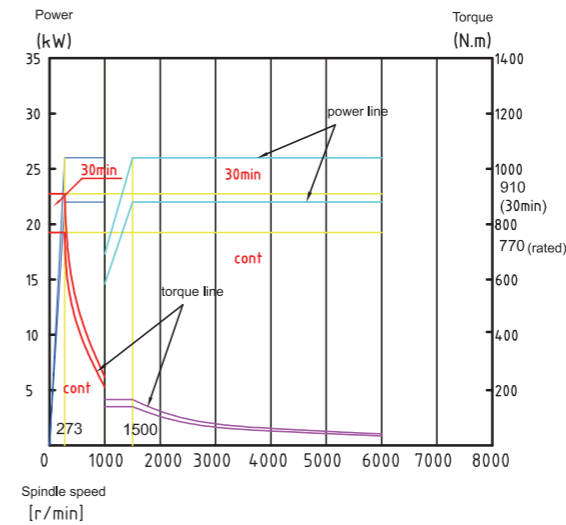

### Standard 8000 r / min spindle

Spindle speed : 8000 r/min  
 Standard : 22/26 kW  
 Spindle Torque : 560/661 Nm  
 Cutting Speed : 12 m/min

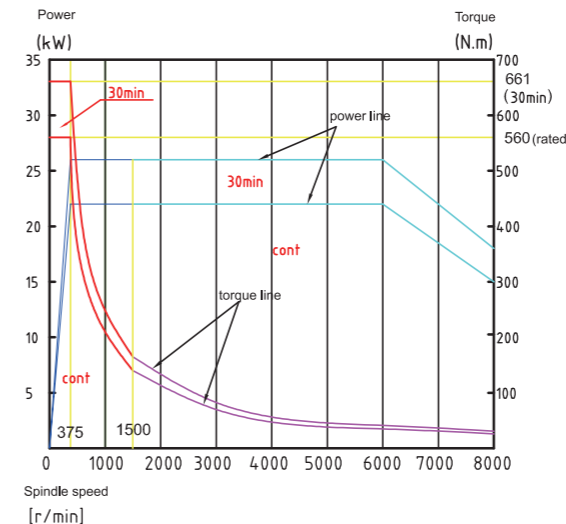

Overall Dimension

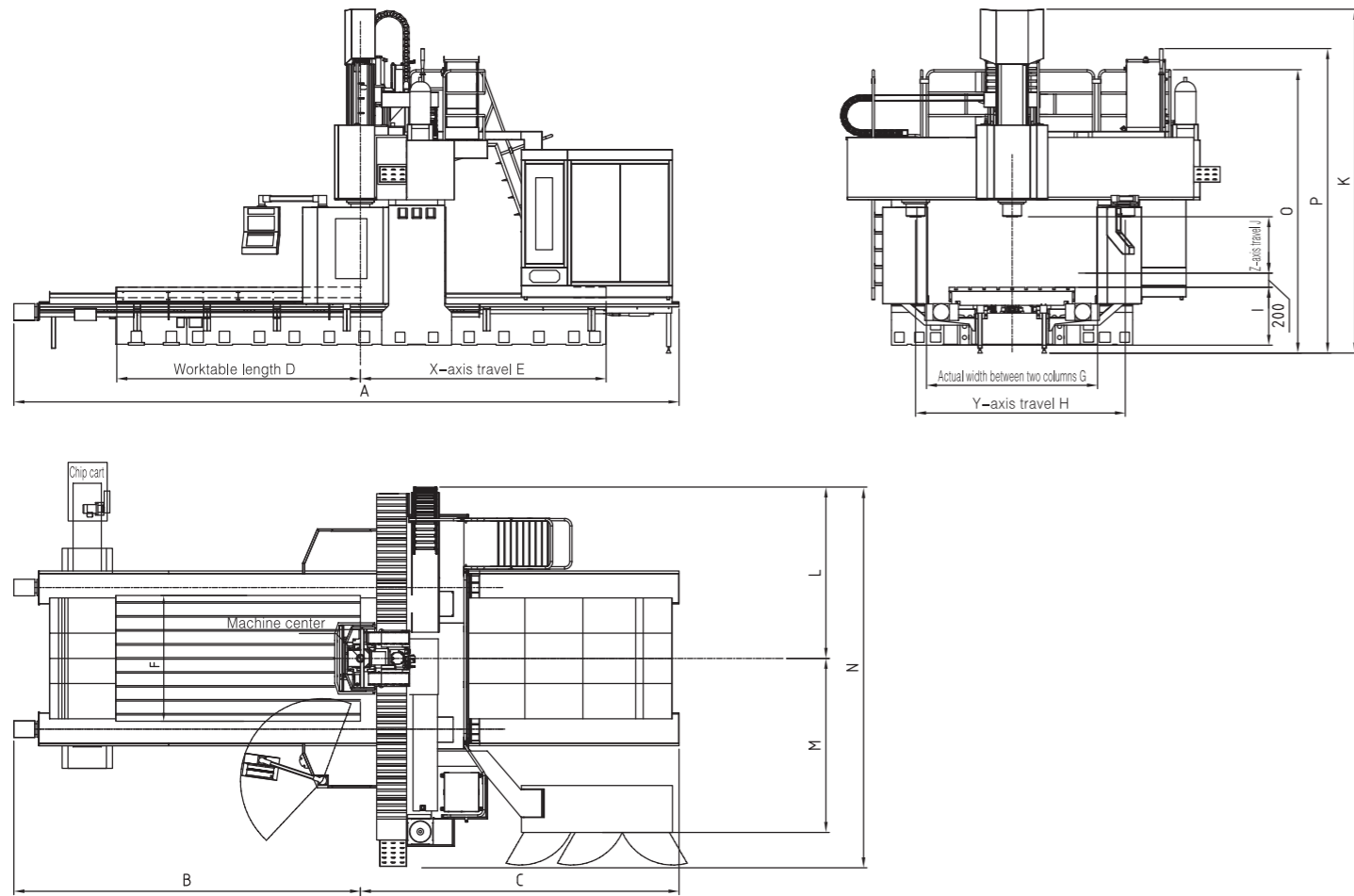

Model	A	B	C	D	E	F	G	H	I	J	K	L	M	N	O	P	weight T
G3524L	10800	6240	4560	3500	3500	1800	2400	3000	830	850	5000	2450	2490	5800	3700	4200	33
G6532L	16800	9000	7800	6500	6500	2800	3200	3800	1050	1050	5900	2950	2890	6500	5200	5270	67

Standard Configuration

- CNC Controller: Fanuc OI MF(1)
- 2-level Gearbox
- Z-axis hydraulic balance system
- Spindle constant-temp cooling system
- Pneumatic, hydraulic, centralized lubrication system
- Auto chip removing system
- Partial Protection Hood

- Workpiece water cooling system
- Air Gun
- Tricolour Light, working light
- Standard accessories and files
- Foundation setting accessories
- Common maintenance tools

Process Range

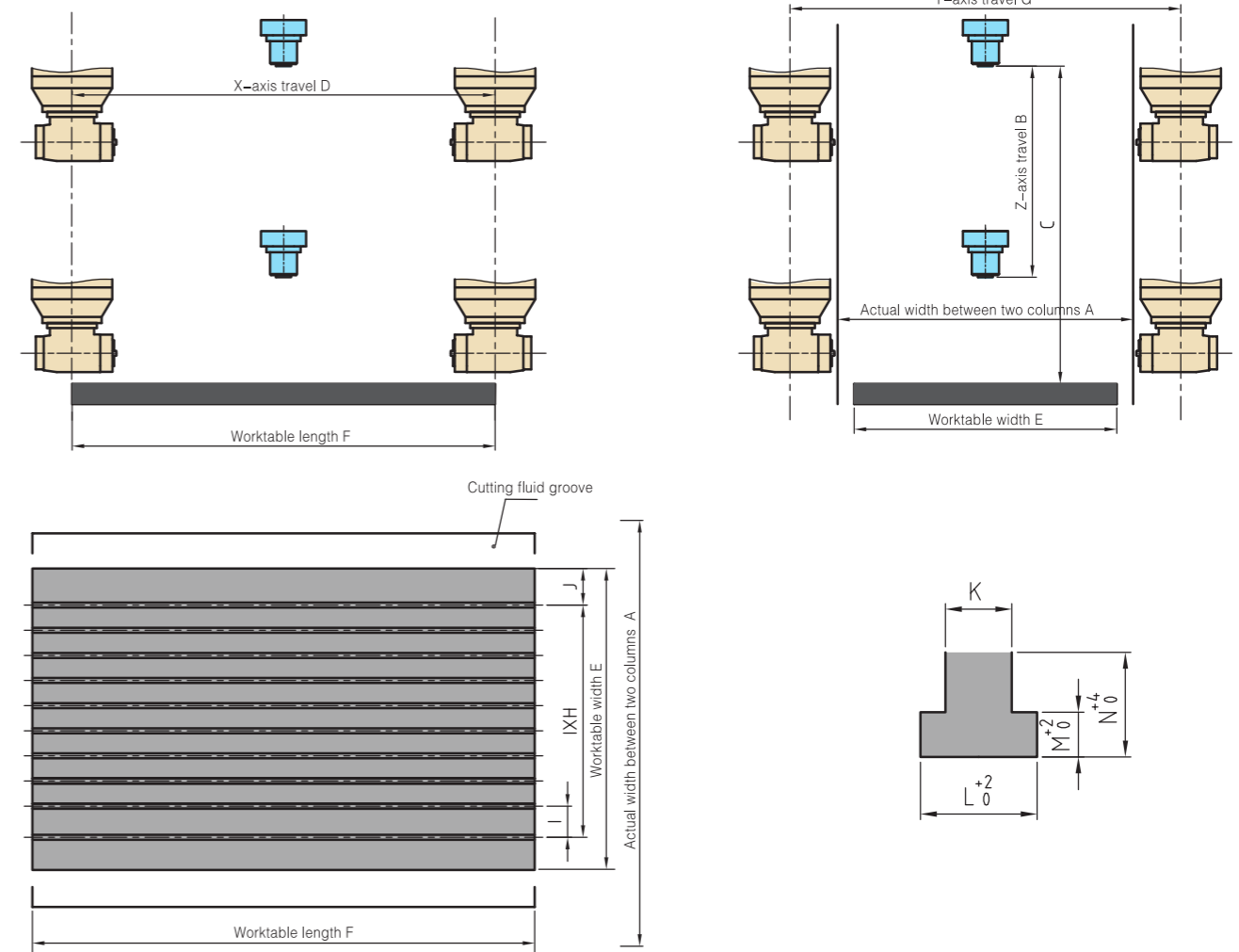

Model	A	B	C	D	E	F	G	H	I	J	K	L	M	N
G3524L	2400	850	1050	3500	1800	3500	3000	9	200	100	22	37	16	38
G6532L	3200	1050	1250	6500	2800	6500	3800	14	200	200	22	37	16	38

Options

- CNC controller: Fanuc 31i; Siemens 828D/848DsI
- Disk-type ATC 24T/30T
- Chain-type ATC 32T/40T
- Vertical-horizontal ATC 40T/60T
- Column height increase by 200mm
- Z-axis travel extend by 200mm
- CTS
- Full protection hood/closed cover
- Full-loop linear scale

- Manual milling head
- Auto milling head
- Auto milling head magazine
- Manual milling head magazine
- Workpiece auto measure device
- Tool auto measure device
- Water Gun
- Spindle outside coolant

Technical specifications		G3024L	G3524L	G4024L	G4524L	G4028L	G4528L
<b>Travel</b>							
Distance between columns	mm	2400	2400	2400	2400	2800	2800
X-axis	mm	3000	3500	4000	4500	4000	4500
Y-axis (processing travel)	mm	3000	3000	3000	3000	3400	3400
Z-axis	mm	850 ( 1050 )	850 ( 1050 )	850 ( 1050 )	850 ( 1050 )	1050 ( 1250 )	1050 ( 1250 )
Distance from table surface to spindle nose	mm	200–1050 ( 200–1250 )	200–1050 ( 200–1250 )	200–1050 ( 200–1250 )	200–1050 ( 200–1250 )	200–1250 ( 200–1450 )	200–1250 ( 200–1450 )
<b>Worktable</b>							
Worktable width	mm	1800	1800	1800	1800	2200	2200
T-slot	mm	22	22	22	22	22	22
Load capacity	t	15	16	18	20	20	22
<b>Spindle</b>							
Spindle type		Direct Drive + Gear Reducer	Direct Drive + Gear Reducer	Direct Drive + Gear Reducer	Direct Drive + Gear Reducer	Direct Drive + Gear Reducer	Direct Drive + Gear Reducer
Spindle taper		BT50	BT50	BT50	BT50	BT50	BT50
Spindle speed	rpm	8000	8000	8000	8000	6000	6000
Spindle power	kW	22/26	22/26	22/26	22/26	22/26	22/26
Torque	N.m	560/661	560/661	560/661	560/661	770/910	770/910
Spindle box section	mm	400 × 400	400 × 400	400 × 400	400 × 400	450 × 450	450 × 450
<b>Feedrate</b>							
Rapid traverse X	m/min	16	16	16	16	12	12
Rapid traverse Y	m/min	16	16	16	16	12	12
Rapid traverse Z	m/min	16	16	16	16	12	12
Cutting speed	m/min	8	8	8	8	8	8
<b>ATC(option)</b>							
ATC type		disk/chain/V&H	disk/chain/V&H	disk/chain/V&H	disk/chain/V&H	disk/chain/V&H	disk/chain/V&H
ATC capacity		24/32/40	24/32/40	24/32/40	24/32/40	24/32/40/60	24/32/40/60
Tool holder type		BT50	BT50	BT50	BT50	BT50	BT50
<b>ISO accuracy GB ( 20±0.5℃ )</b>							
Positioning X	mm	0.024	0.027	0.028	0.031	0.028	0.031
Positioning Y	mm	0.024	0.024	0.024	0.024	0.026	0.026
Positioning Z	mm	0.02	0.02	0.02	0.02	0.02	0.02
Repeatability X	mm	0.016	0.017	0.018	0.02	0.018	0.02
Repeatability Y	mm	0.016	0.016	0.016	0.016	0.017	0.017
Repeatability Z	mm	0.008	0.008	0.008	0.008	0.008	0.008
<b>Others</b>							
Power	kVA	50	50	50	50	50	50
Air pressure	kgf/cm <sup>2</sup>	6.5	6.5	6.5	6.5	6.5	6.5
Height	mm	5000	5000	5000	5000	5900	5900
Floor area	mm × mm	9800X5800	10800X5800	11800X5800	12800X5800	11800X6600	12800X6600
Net weight	t	30	33	36.5	40	45	47
Controller	FANUC/SIEMENS						

Technical specifications		G5532L	G6532L	G6537L	G8537L	G10537L
<b>Travel</b>						
Distance between columns	mm	3200	3200	3700	3700	3700
X-axis	mm	5500	6500	6500	8500	10500
Y-axis (processing travel)	mm	3800	3800	4200	4200	4200
Z-axis	mm	1050 ( 1250 )	1050 ( 1250 )	1050 ( 1250 )	1050 ( 1250 )	1050 ( 1250 )
Distance from table surface to spindle nose	mm	200–1250 ( 200–1450 )	200–1250 ( 200–1450 )	200–1250 ( 200–1450 )	200–1250 ( 200–1450 )	200–1250 ( 200–1450 )
<b>Worktable</b>						
Worktable width	mm	2800	2800	3500	3500	3500
T-slot	mm	22	22	28	28	28
Load capacity	t	28	32	32	36	40
<b>Spindle</b>						
Spindle type		Direct Drive + Gear Reducer	Direct Drive + Gear Reducer	Direct Drive + Gear Reducer	Direct Drive + Gear Reducer	Direct Drive + Gear Reducer
Spindle taper		BT50	BT50	BT50	BT50	BT50
Spindle speed	rpm	6000	6000	6000	6000	6000
Spindle power	kW	22/26	22/26	22/26	22/26	22/26
Torque	N.m	770/910	770/910	770/910	770/910	770/910
Spindle box section	mm	450 × 450	450 × 450	450 × 450	450 × 450	450 × 450
<b>Feedrate</b>						
Rapid traverse X	m/min	12	12	10	10	10
Rapid traverse Y	m/min	12	12	12	12	12
Rapid traverse Z	m/min	12	12	12	12	12
Cutting speed	m/min	8	8	6	6	6
<b>ATC(option)</b>						
ATC type		disk/chain/V&H	disk/chain/V&H	disk/chain/V&H	disk/chain/V&H	disk/chain/V&H
ATC capacity		24/32/40/60	24/32/40/60	24/32/40/60	24/32/40/60	24/32/40/60
Tool holder type		BT50	BT50	BT50	BT50	BT50
<b>ISO accuracy GB ( 20±0.5℃ )</b>						
Positioning X	mm	0.035	0.039	0.039	0.047	0.055
Positioning Y	mm	0.028	0.028	0.029	0.029	0.029
Positioning Z	mm	0.02	0.02	0.02	0.02	0.02
Repeatability X	mm	0.022	0.024	0.024	0.029	0.034
Repeatability Y	mm	0.018	0.018	0.019	0.019	0.019
Repeatability Z	mm	0.008	0.008	0.008	0.008	0.008
<b>Others</b>						
Power	kVA	50	50	50	50	50
Air pressure	kgf/cm <sup>2</sup>	6.5	6.5	6.5	6.5	6.5
Height	mm	5900	5900	6100	6100	6100
Floor area	mm × mm	14800X7000	16800X7000	16800X7500	20800X7500	24800X7500
Net weight	t	63	67	86	102	118
Controller		FANUC/SIEMENS				



## GMC series

### High performance Gantry Machining Center

GMC series are designed for mould production, with 3-axis linear guideway and high speed motorized spindle, the machines can be widely used in precise moulds manufacture industries.

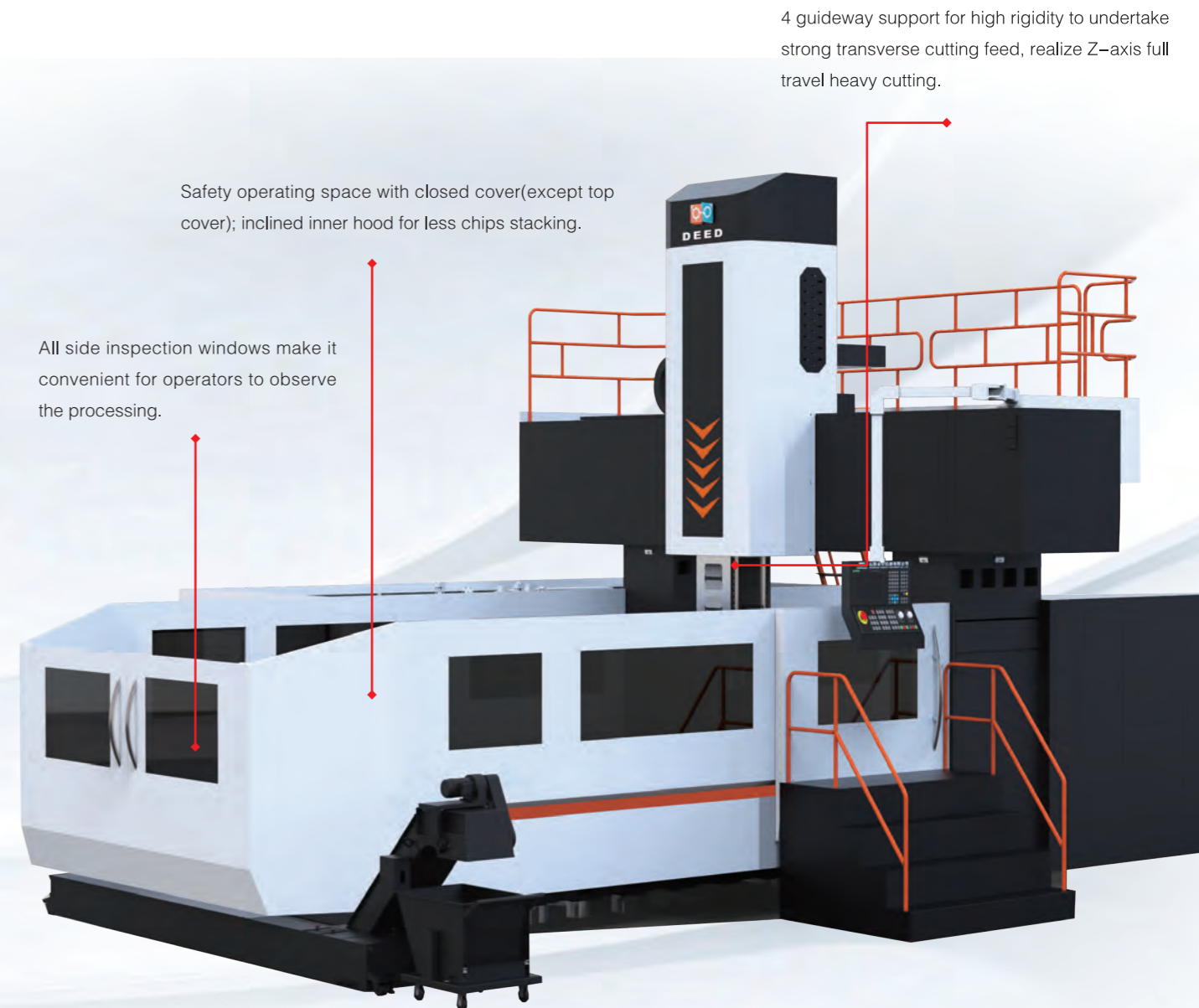

4 guideway support for high rigidity to undertake strong transverse cutting feed, realize Z-axis full travel heavy cutting.

Safety operating space with closed cover(except top cover); inclined inner hood for less chips stacking.

All side inspection windows make it convenient for operators to observe the processing.

## High Rigidity Design for Full Travel Processing

Machine bed and columns are casted by new material and new technology of UHPC from Germany. Compared to normal grey casting, they can get better vibration absorption, lower heat expansivity and lower thermal conductivity.

Machine beam, slider and headstock are welded in steel-board welding technology from Germany, they can get higher rigidity, lighter moving parts, less movement inertia, then the machine can get better response rate and movement precision.

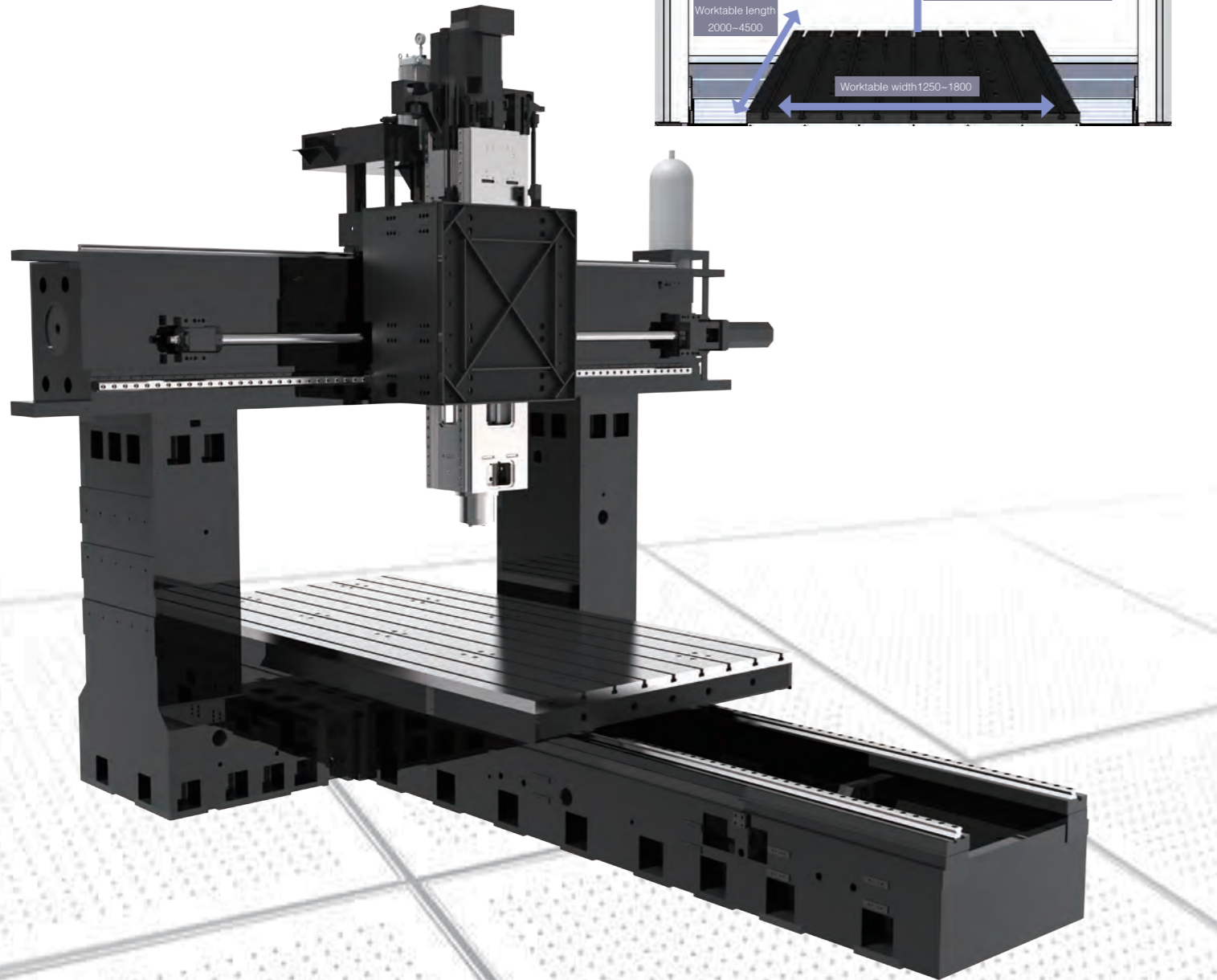
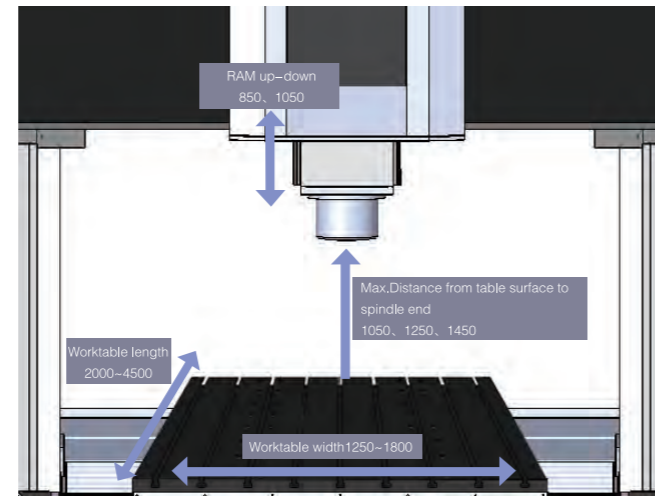

## Direct-drive Spindle



Standard 8000 r / min spindle speed

spindle speed : 8000 r/min  
 main motor power : 22/26 kW  
 spindle torque : 560/661Nm  
 cutting speed : 12 m/min

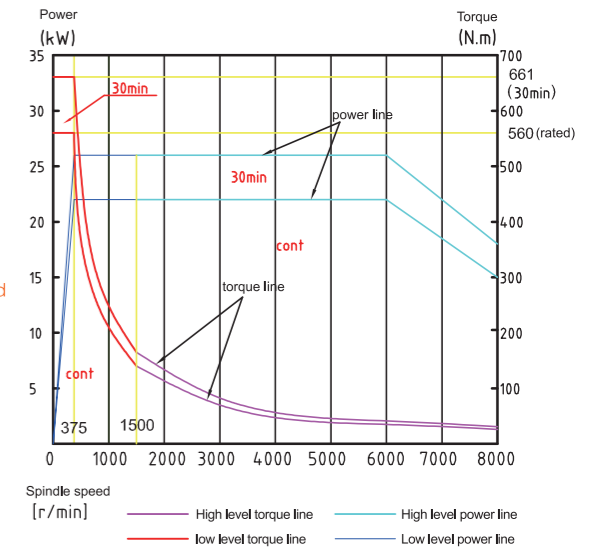

## Motorized Spindle

High speed motorized spindle, with air-oil lubricated bearings for precise feeding and compressed air for heat releasing.

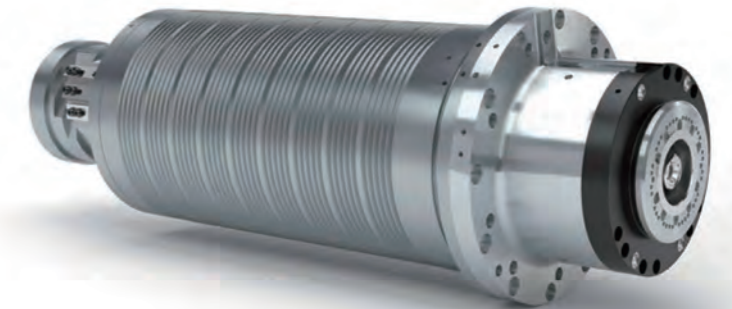

Optional 12000r/min spindle speed

spindle speed : 12000 r/min  
 main motor power : 25/44 kW  
 spindle torque : 87/150Nm

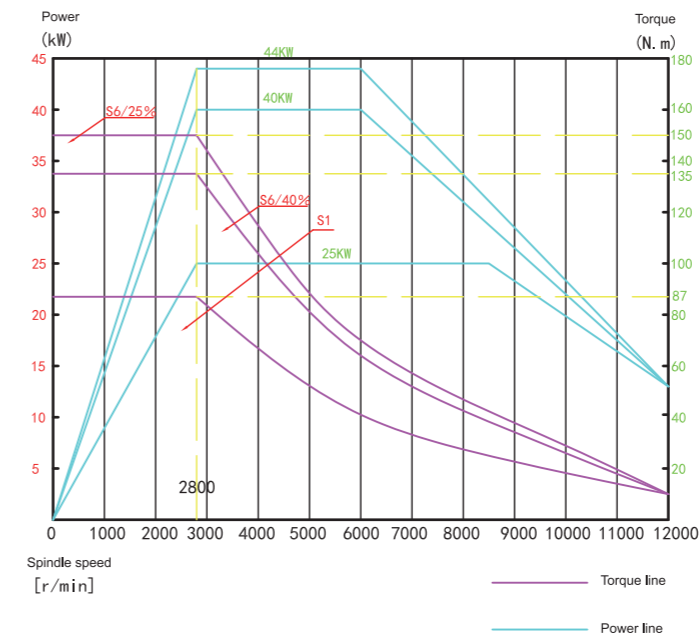



Overall Dimension

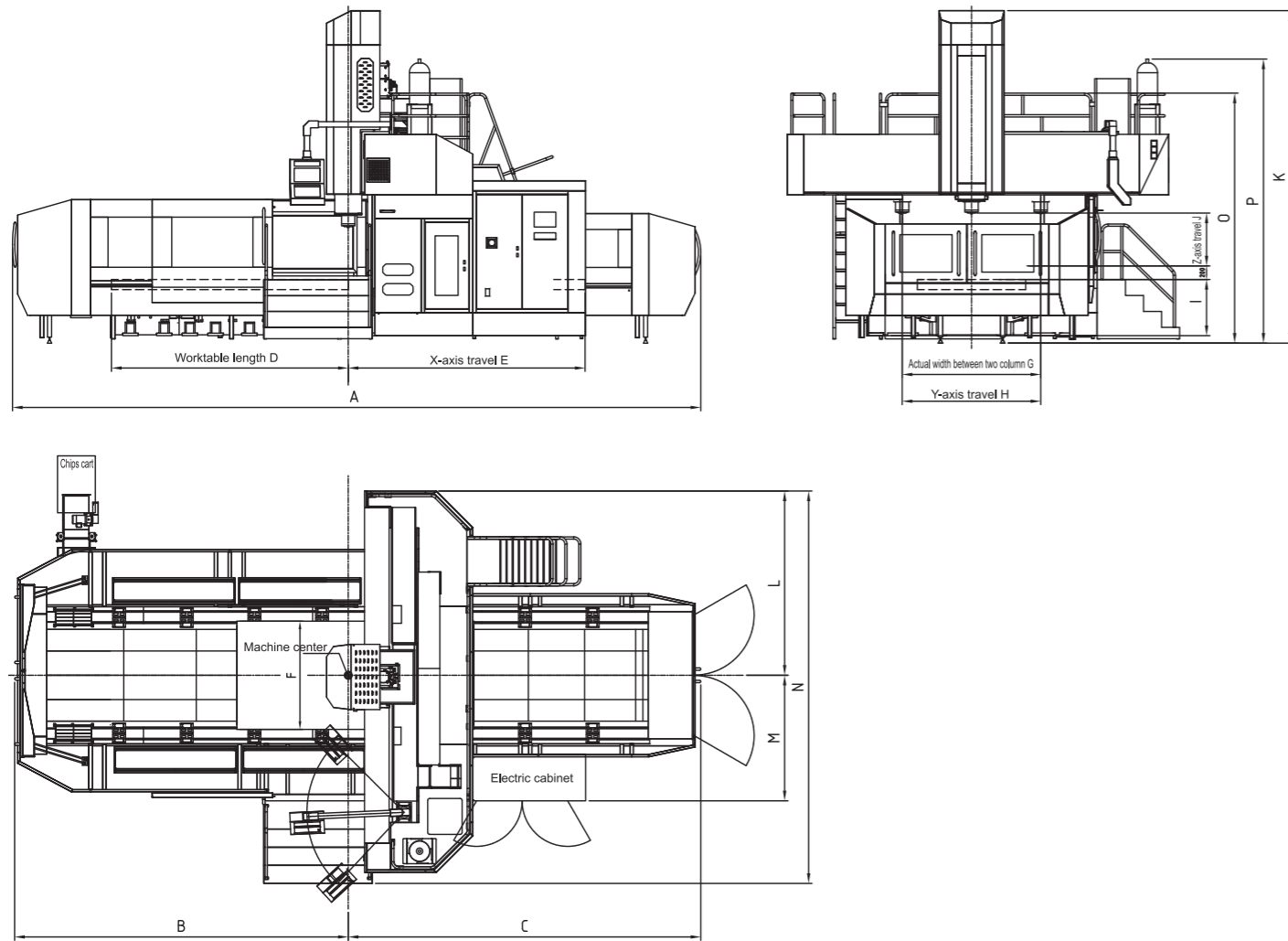

Model	A	B	C	D	E	F	G	H	I	J	K	L	M	N	O	P	Weight	T
GMC2516L	7850	4035	3815	2500	2500	1250	1600	1600	930	850	5100	2120	1655	4955	3700	4200	26	
GMC3020L	9000	4555	4445	3000	3000	1600	2000	2000	930	850	5100	2320	1855	5400	3700	4200	28	
GMC3524L	10250	5000	5250	3500	3500	1800	2400	2400	930	850	5100	2520	2055	5800	3700	4200	33	

Process Range

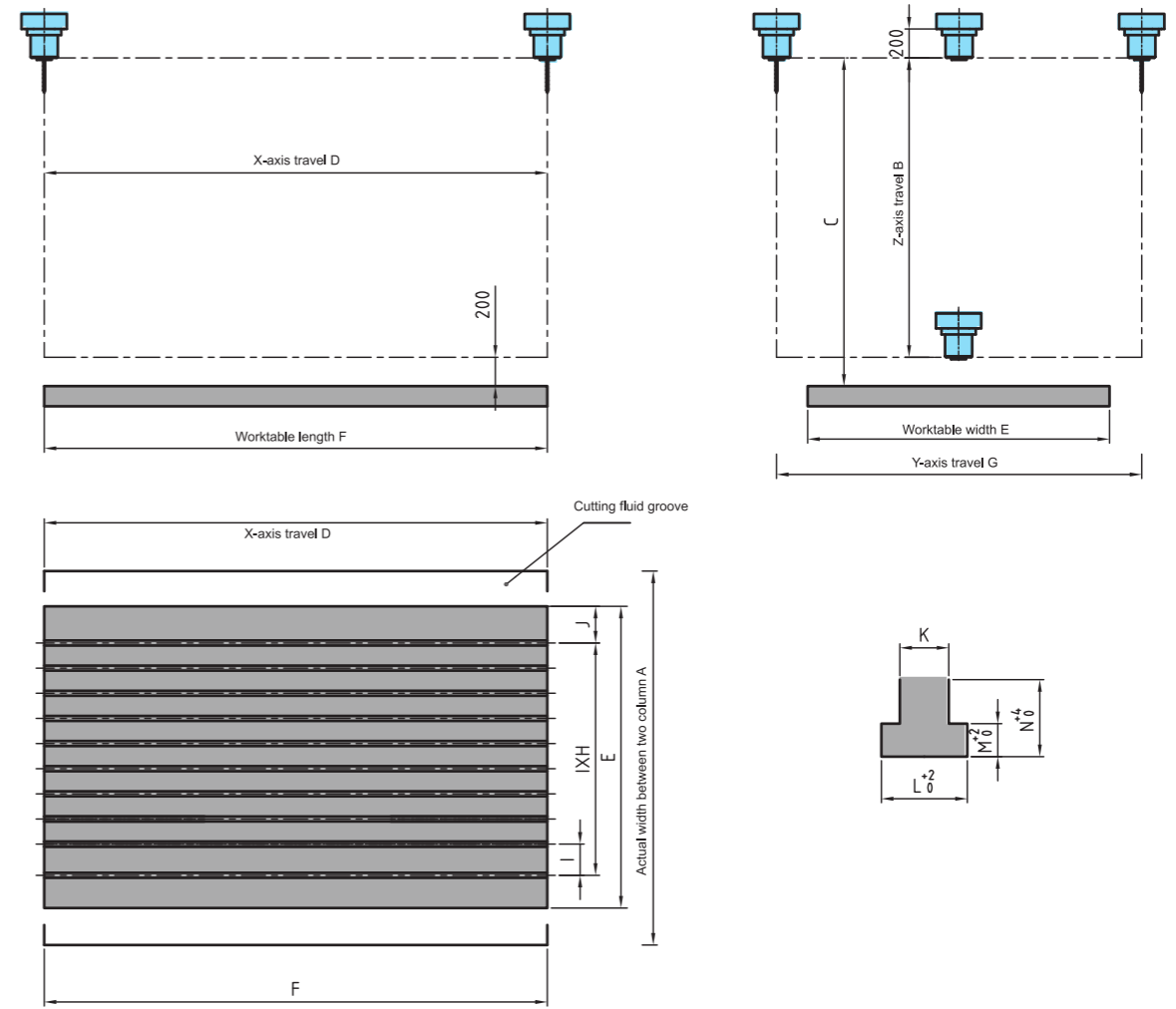

Model	A	B	C	D	E	F	G	H	I	J	K	L	M	N
GMC2516L	1600	850	1050	2500	1250	2500	1600	8	160	80	22	37	16	38
GMC3020L	2000	850	1050	3000	1600	3000	2000	10	160	80	22	37	16	38
GMC3524L	2400	850	1050	3500	1800	3500	2400	9	200	100	22	37	16	38

Standard Configuration

- CNC Controller: FANUC Oi MF(1)
- 2-level Gearbox
- Z-axis hydraulic balance system
- Spindle constant-temp cooling system
- Centralized Lubrication System for linear guideway & ballscrewLubrication system
- Auto Chip removing systems
- Full Cover

- Workpiece water cooling system
- Air Gun
- Tricolour Light working light
- Standard accessories and files
- Foundation setting accessories
- Common maintenance tools

Options

- CNC controller: FANUC 31i ,Siemens 828D /840DsI
- 12000rpm Motorized spindle(HSK-A63)
- Disk-type ATC 24T/30T
- Chain-type ATC 32T/40T
- Column height increase by 200mm
- Column height increase by 400mm
- Z-axis travel
- CTS

- Spindle outside coolant
- Full closed cover(including top)
- Full-loop linear scale
- Workpiece auto measure device
- Tool auto measure device
- Cutting Oil&mist collector
- Water Gun

Technical specifications		GMC2016L	GMC2516L	GMC3016L	GMC3516L	GMC4016L	GMC2020L	GMC2520L
<b>Travel</b>								
Distance between columns	mm	1600	1600	1600	1600	1600	2000	2000
X-axis	mm	2000	2500	3000	3500	4000	2000	2500
Y-axis (processing travel)	mm	1600	1600	1600	1600	1600	2000	2000
Z-axis	mm	850	850	850	850	850	850	850
Distance from table surface to spindle nose	mm	200-1050(255-1105)	200-1050(255-1105)	200-1050(255-1105)	200-1050(255-1105)	200-1050(255-1105)	200-1050(255-1105)	200-1050(255-1105)
<b>Worktable</b>								
Worktable width	mm	1250	1250	1250	1250	1250	1600	1600
T-slot	mm	22	22	22	22	22	22	22
Load capacity	t	5	6	8	9	10	7	9
<b>Spindle</b>								
Spindle type		Direct Drive + Gearbox ( motorized spindle )	Direct Drive + Gearbox ( motorized spindle )	Direct Drive + Gearbox ( motorized spindle )	Direct Drive + Gearbox ( motorized spindle )	Direct Drive + Gearbox ( motorized spindle )	Direct Drive + Gearbox ( motorized spindle )	Direct Drive + Gearbox ( motorized spindle )
Spindle taper		BT50 ( HSK63 )	BT50 ( HSK63 )	BT50 ( HSK63 )	BT50 ( HSK63 )	BT50 ( HSK63 )	BT50 ( HSK63 )	BT50 ( HSK63 )
Spindle speed	rpm	8000 ( 12000 )	8000 ( 12000 )	8000 ( 12000 )	8000 ( 12000 )	8000 ( 12000 )	8000 ( 12000 )	8000 ( 12000 )
Spindle power	kW	22/26 ( 25/44 )	22/26 ( 25/44 )	22/26 ( 25/44 )	22/26 ( 25/44 )	22/26 ( 25/44 )	22/26 ( 25/44 )	22/26 ( 25/44 )
Torque	N.m	560/661 ( 87/150 )	560/661 ( 87/150 )	560/661 ( 87/150 )	560/661 ( 87/150 )	560/661 ( 87/150 )	560/661 ( 87/150 )	560/661 ( 87/150 )
Spindle box section	mm	400 × 400	400 × 400	400 × 400	400 × 400	400 × 400	400 × 400	400 × 400
<b>Feedrate</b>								
Rapid traverse X	m/min	16	16	16	16	16	16	16
Rapid traverse Y	m/min	20	20	20	20	20	20	20
Rapid traverse Z	m/min	20	20	20	20	20	20	20
Cutting speed	m/min	12	12	12	12	12	12	12
<b>ATC(option)</b>								
ATC type		disk/chain	disk/chain	disk/chain	disk/chain	disk/chain	disk/chain	disk/chain
ATC capacity		24/32/40	24/32/40	24/32/40	24/32/40	24/32/40	24/32/40	24/32/40
Tool holder type		BT50 ( HSK63 )	BT50 ( HSK63 )	BT50 ( HSK63 )	BT50 ( HSK63 )	BT50 ( HSK63 )	BT50 ( HSK63 )	BT50 ( HSK63 )
<b>ISO accuracy GB ( 20±0.5°C )</b>								
Positioning X	mm	0.014	0.016	0.018	0.02	0.021	0.014	0.016
Positioning Y	mm	0.014	0.014	0.014	0.014	0.014	0.014	0.014
Positioning Z	mm	0.011	0.011	0.011	0.011	0.011	0.011	0.011
Repeatability X	mm	0.009	0.011	0.011	0.013	0.014	0.009	0.011
Repeatability Y	mm	0.009	0.009	0.009	0.009	0.009	0.009	0.009
Repeatability Z	mm	0.006	0.006	0.006	0.006	0.006	0.006	0.006
<b>Others</b>								
Power	kVA	60	60	60	60	60	60	60
Air pressure	kgf/cm <sup>2</sup>	6.5	6.5	6.5	6.5	6.5	6.5	6.5
Height	mm	5100	5100	5100	5100	5100	5100	5100
Floor area	mm × mm	7520 × 4955	7850 × 4955	9000 × 4955	10250 × 4955	11250 × 4955	7520 × 5400	7850 × 5400
Net weight	t	24	26	27.5	29.5	35	25	27
Controller	FANUC/SIEMENS							

Technical specifications		GMC3020L	GMC3520L	GMC4020L	GMC3024L	GMC3524L	GMC4024L	GMC4524L
<b>Travel</b>								
Distance between columns	mm	2000	2000	2000	2400	2400	2400	2400
X-axis	mm	3000	3500	4000	3000	3500	4000	4500
Y-axis (processing travel)	mm	2000	2000	2000	2400	2400	2400	2400
Z-axis	mm	850	850	850	850	850	850	850
Distance from table surface to spindle nose	mm	200–1050(255–1105)	200–1050(255–1105)	200–1050(255–1105)	200–1050(255–1105)	200–1050(255–1105)	200–1050(255–1105)	200–1050(255–1105)
<b>Worktable</b>								
Worktable width	mm	1600	1600	1600	1800	1800	1800	1800
T-slot	mm	22	22	22	22	22	22	22
Load capacity	t	11	13	14	13	14	16	18
<b>Spindle</b>								
Spindle type		Direct Drive + Gearbox ( motorized spindle )	Direct Drive + Gearbox ( motorized spindle )	Direct Drive + Gearbox ( motorized spindle )	Direct Drive + Gearbox ( motorized spindle )	Direct Drive + Gearbox ( motorized spindle )	Direct Drive + Gearbox ( motorized spindle )	Direct Drive + Gearbox ( motorized spindle )
Spindle taper		BT50 ( HSK63 )	BT50 ( HSK63 )	BT50 ( HSK63 )	BT50 ( HSK63 )	BT50 ( HSK63 )	BT50 ( HSK63 )	BT50 ( HSK63 )
Spindle speed	rpm	8000 ( 12000 )	8000 ( 12000 )	8000 ( 12000 )	8000 ( 12000 )	8000 ( 12000 )	8000 ( 12000 )	8000 ( 12000 )
Spindle power	kW	22/26 ( 25/44 )	22/26 ( 25/44 )	22/26 ( 25/44 )	22/26 ( 25/44 )	22/26 ( 25/44 )	22/26 ( 25/44 )	22/26 ( 25/44 )
Torque	N.m	560/661 ( 87/150 )	560/661 ( 87/150 )	560/661 ( 87/150 )	560/661 ( 87/150 )	560/661 ( 87/150 )	560/661 ( 87/150 )	560/661 ( 87/150 )
Spindle box section	mm	400 × 400	400 × 400	400 × 400	400 × 400	400 × 400	400 × 400	400 × 400
<b>Feedrate</b>								
Rapid traverse X	m/min	16	16	16	16	16	16	16
Rapid traverse Y	m/min	20	20	20	16	16	16	16
Rapid traverse Z	m/min	20	20	20	16	16	16	16
Cutting speed	m/min	12	12	12	12	12	12	12
<b>ATC(option)</b>								
ATC type		disk/chain	disk/chain	disk/chain	disk/chain	disk/chain	disk/chain	disk/chain
ATC capacity		24/32/40	24/32/40	24/32/40	24/32/40	24/32/40	24/32/40	24/32/40
Tool holder type		BT50 ( HSK63 )	BT50 ( HSK63 )	BT50 ( HSK63 )	BT50 ( HSK63 )	BT50 ( HSK63 )	BT50 ( HSK63 )	BT50 ( HSK63 )
<b>ISO accuracy GB ( 20±0.5°C )</b>								
Positioning X	mm	0.018	0.02	0.021	0.018	0.02	0.021	0.023
Positioning Y	mm	0.014	0.014	0.014	0.016	0.016	0.016	0.016
Positioning Z	mm	0.011	0.011	0.011	0.011	0.011	0.011	0.011
Repeatability X	mm	0.011	0.013	0.014	0.011	0.013	0.014	0.015
Repeatability Y	mm	0.009	0.009	0.009	0.01	0.01	0.01	0.01
Repeatability Z	mm	0.006	0.006	0.006	0.006	0.006	0.006	0.006
<b>Others</b>								
Power	kVA	60	60	60	60	60	60	60
Air pressure	kgf/cm <sup>2</sup>	6.5	6.5	6.5	6.5	6.5	6.5	6.5
Height	mm	5100	5100	5100	5100	5100	5100	5100
Floor area	mm × m	9000 × 5400	10250 × 5400	11250 × 5400	9000 × 5800	10250 × 5800	11250 × 5800	12250 × 5800
Net weight	m	28	31	36	32	35	38.5	42
Controller	FANUC/SIEMENS							

**ATC** With optional disk type, chain type and vertical–horizontal type tool magazine, can realize auto tool change for higher efficiency.

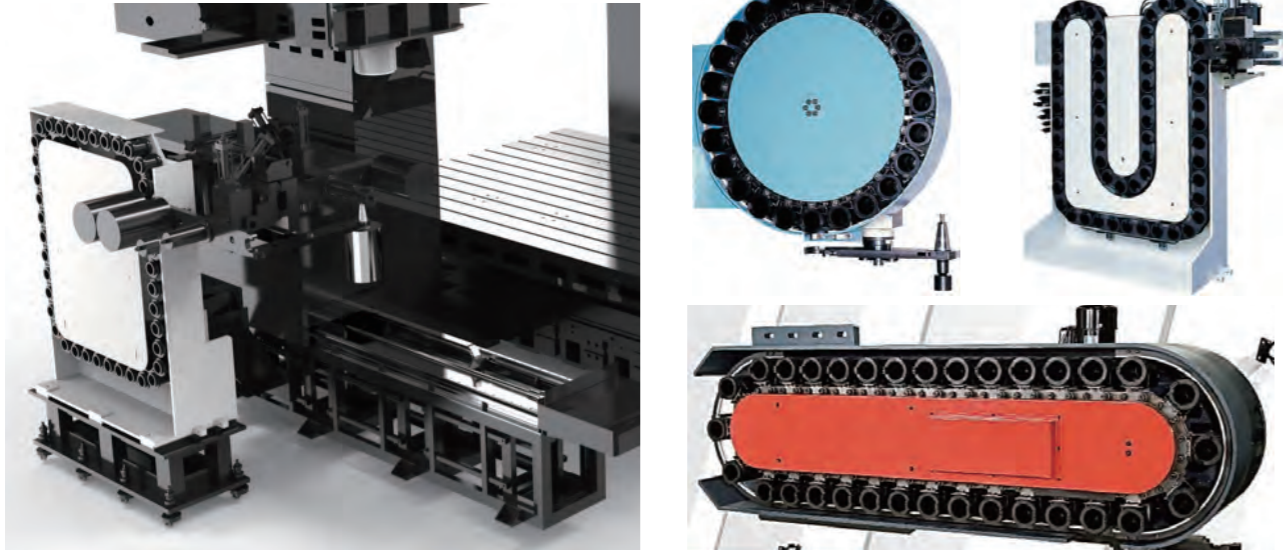

## TEL: 400-113-6699 24/7 Non-stop Service

After–sales maintenance every 3 months within warranty  
40 sales & after–sale service offices globally  
After–sales engineer with average 10 years experience  
95% spare parts available at each after–sales office  
Complete training and operation guiding  
Standard after–sales service processing



**AAC** With closed automatic head magazine, can realize all milling heads changeable for automatic multisurface processing.

Extend 90°milling head

90°milling head

Extend milling head

Universal milling head

